

DURATRAY

cable basket

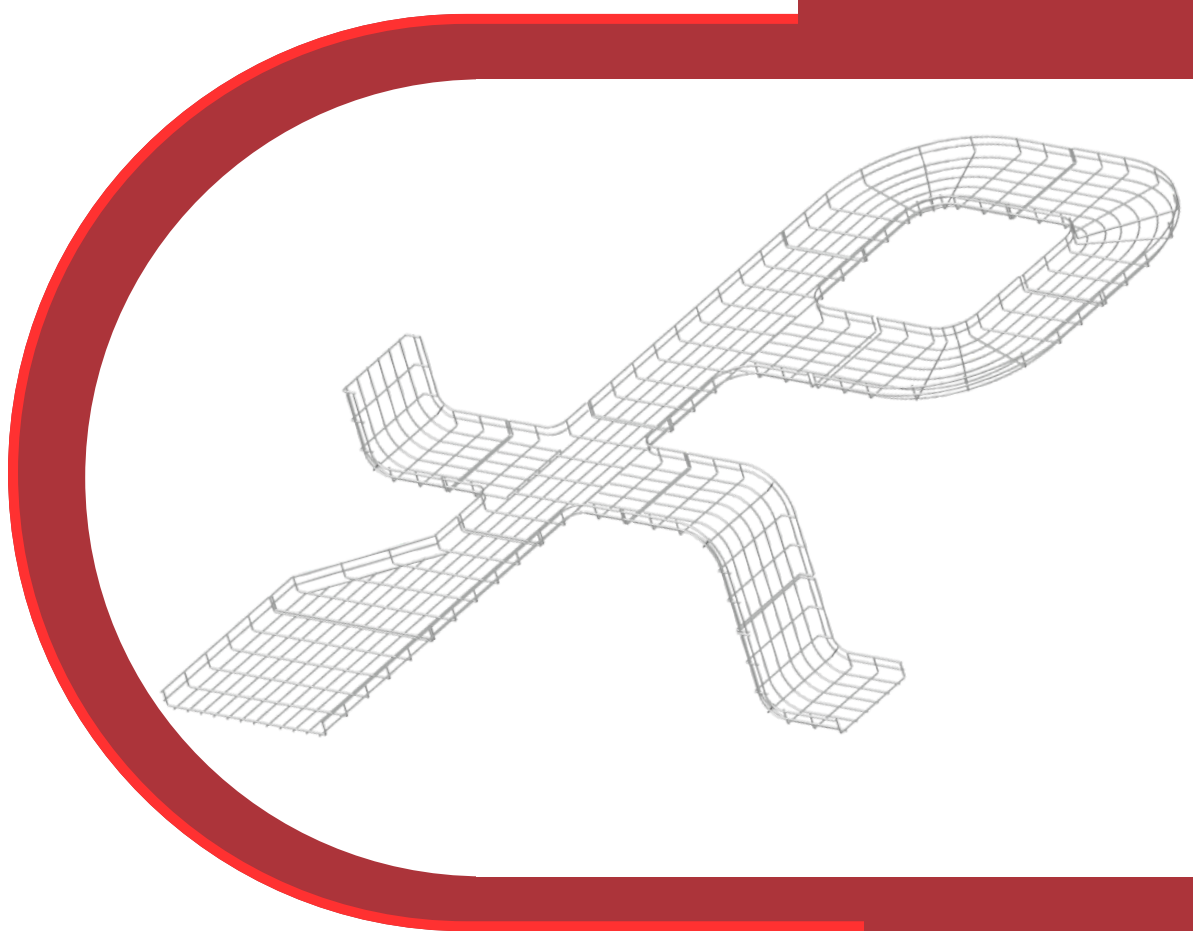

DURATRAY CO.,LTD. | บริษัท ดุราเทรย์ จำกัด

ACS
REGISTRARS
Quality Assurance
ISO 9001



229

Material	Description	Order Code
304	Stainless Steel SUS304, Recommended Applications for Food preparation, Wash - down areas	S
304L	Stainless Steel SUS304L, Recommended Applications for Food preparation, Wash - down areas	SL
316	Stainless Steel SUS316, Recommended Applications for Highly corrosive applications & marine environments	SS
316L	Stainless Steel SUS316L, Recommended Applications for Highly corrosive applications & marine environments	SSL
EZ	Low Carbon Steel SWRM12 with Electro Zinc Coated (Applied after fabrication), Recommended applications for Controlled interior. Average thickness approximately 20-25 microns.	Z
HDG	Low Carbon Steel SWRM12 with Hot Dip Galvanized (Applied after fabrication), Recommended applications for Exterior, corrosive. Average thickness approximately 80 microns.	H
PC	Low Carbon Steel SWRM12 with Powder Coated (Applied after fabrication), Recommended applications for Controlled interior. Average thickness approximately 80-100 microns	P
GS	Galvanized Sheet	GS

Icons Description



Product designed for hygienic area.



Product is cleaned by Electro Polishing Method for hygienic area



Safety Edge Chamfering



Duratray Patented



Boltless Installation



Bend and Lock



Safe Working Load (SWL)



ISO 9001-2015 Management Systems Certified



Salt Spray Tested according to ASTM B117 standard by National Metal and Materials Technology Center



Loading and deflection characteristics of the Cable baskets tested according to NEMA VE1 Standard.



Loading and deflection characteristics of the Cable baskets tested according to IEC61537 Standard.



UL Standard.



DURATRAY

CABLE BASKET

**WALL MOUNTED
SUPPORT FOR REDUCING
DUST ACCUMULATION.**

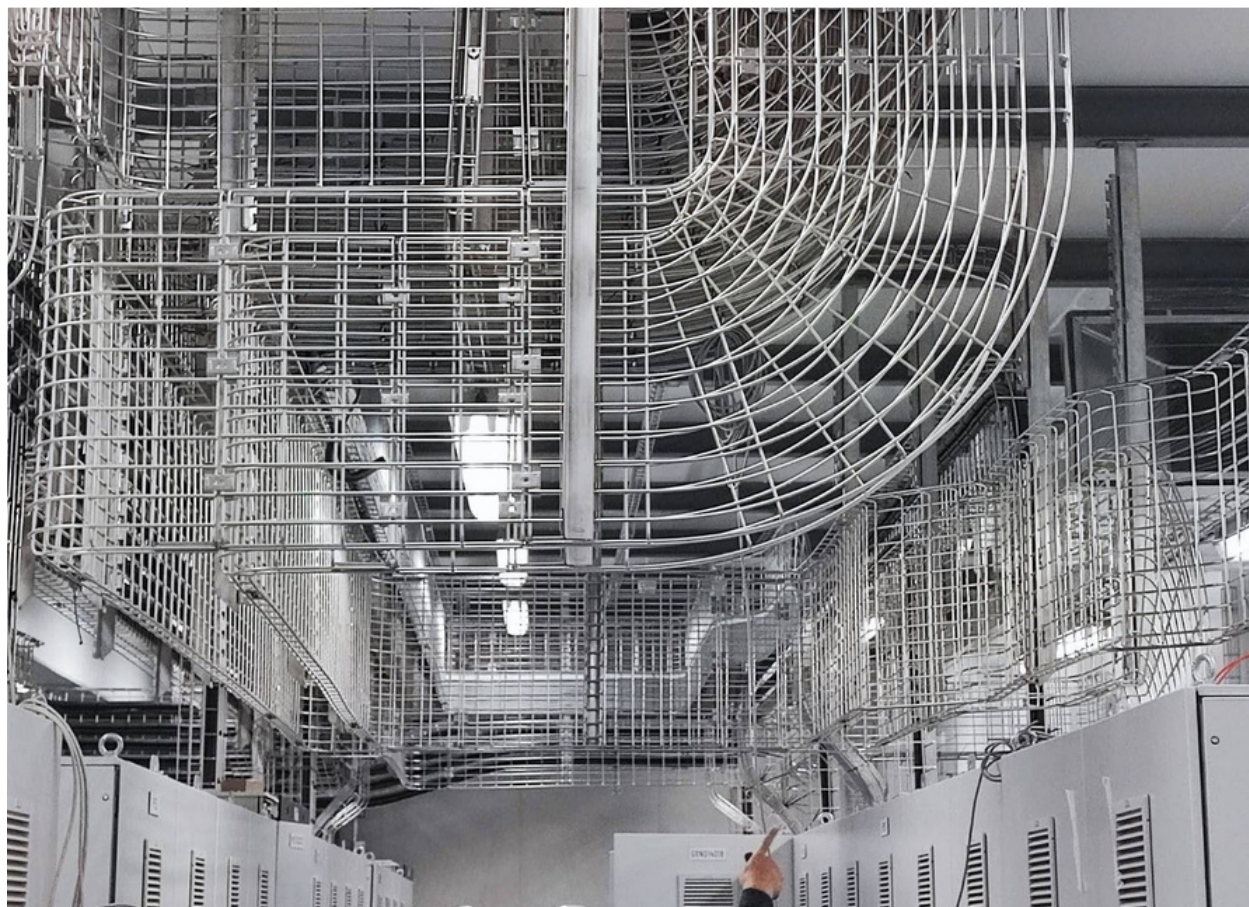
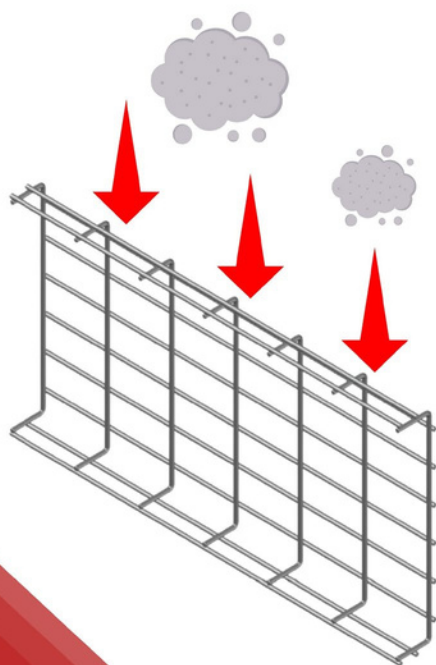

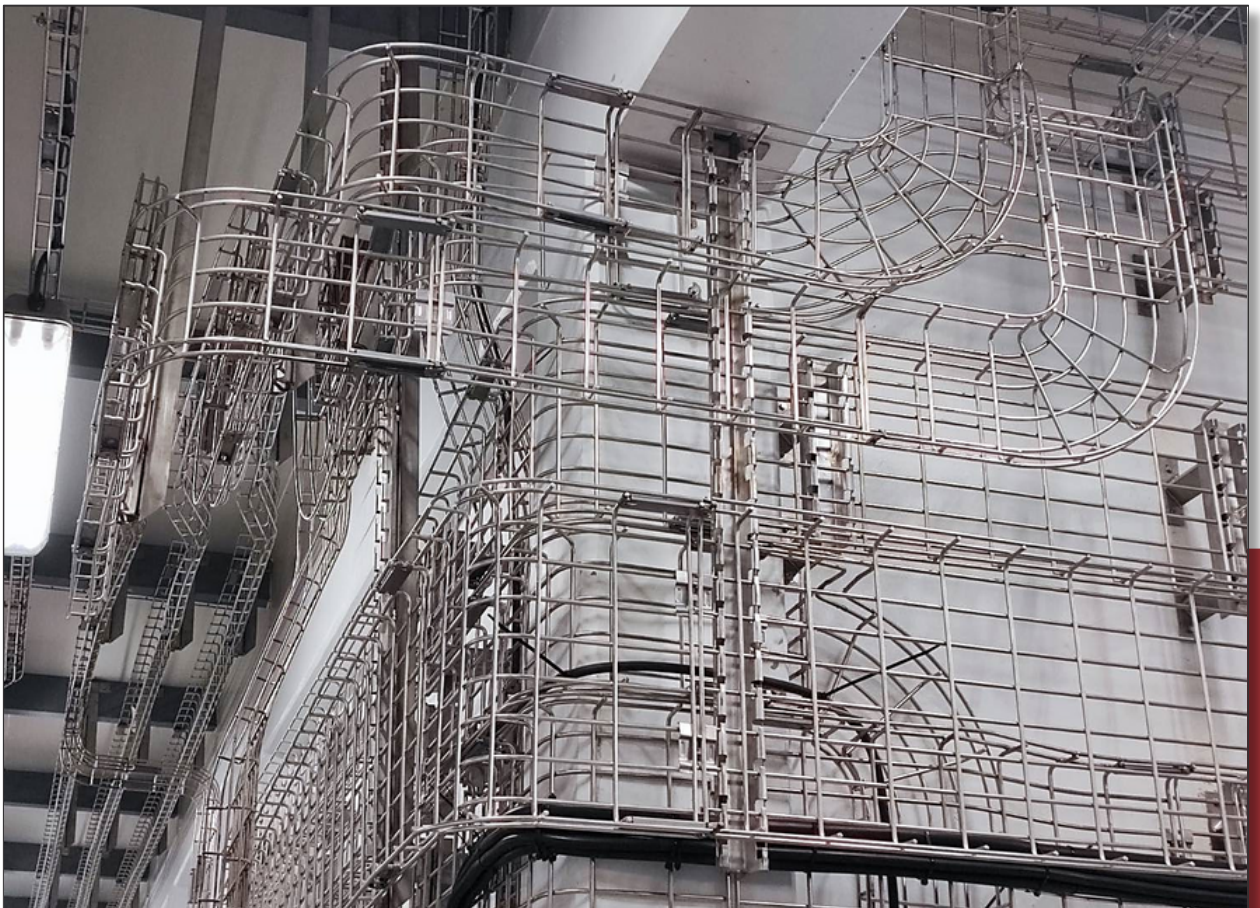

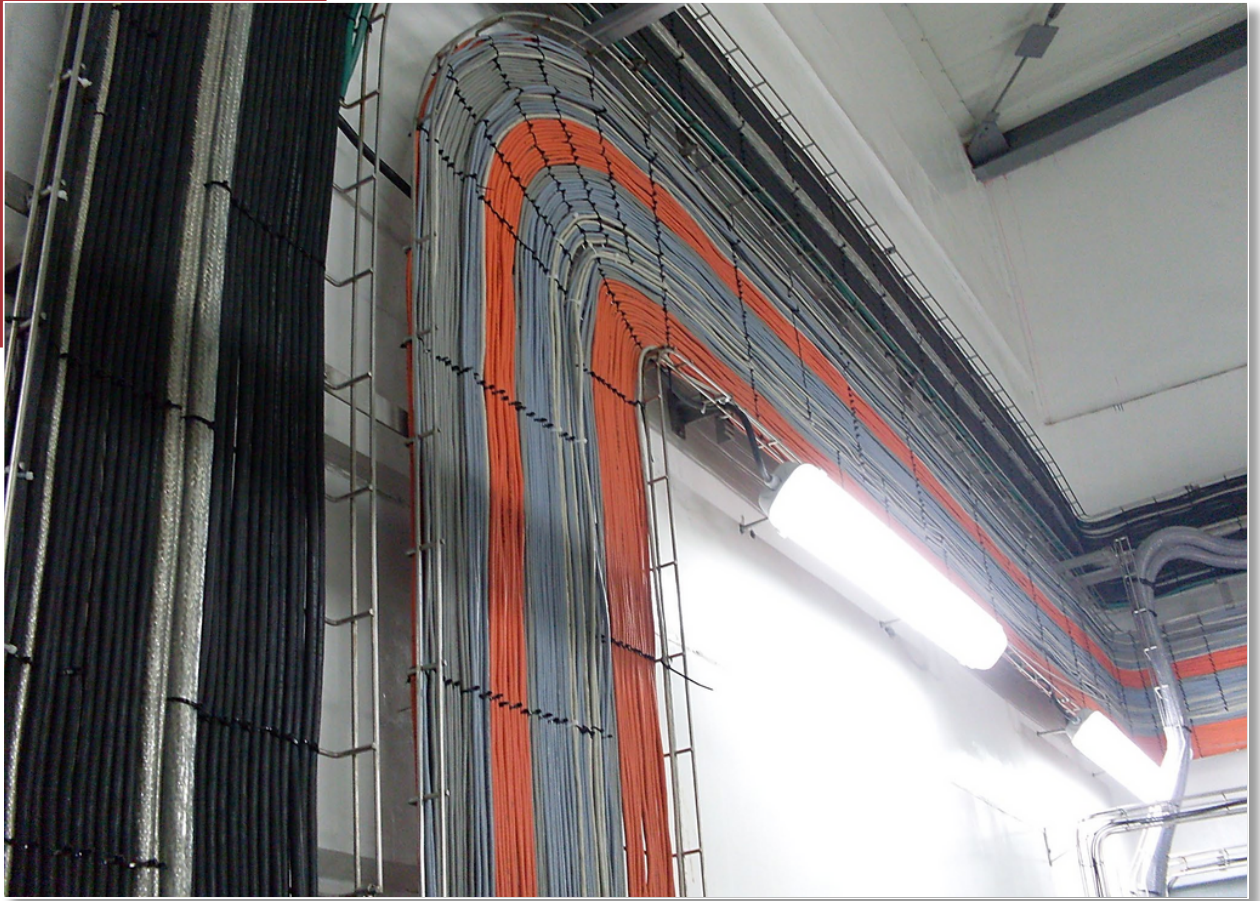



DURATRAY

Technical

FINISHING FOR THE FOOD INDUSTRY

MEETING INDUSTRY STANDARDS FOR SANITATION IN THE FOOD INDUSTRY

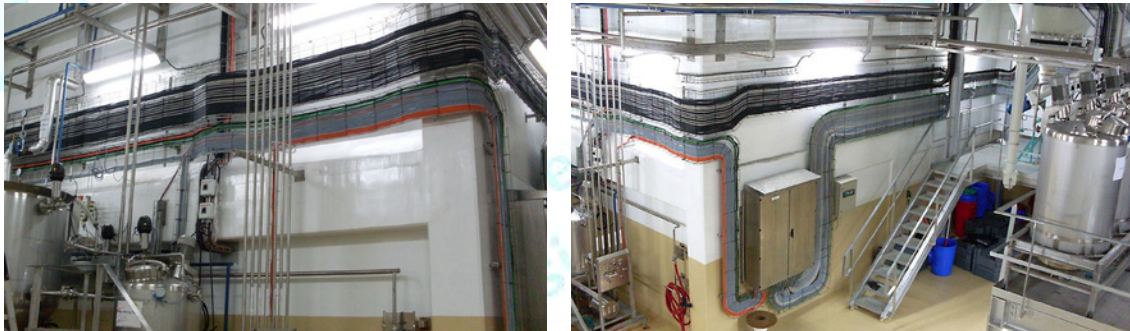

HOW THE FOOD INDUSTRY BENEFITS FROM ELECTROPOLISHING

In the world of food service equipment manufacturing, corrosion resistance and cleanability are key. Electropolishing helps insure that both of these requirements are met. When a part is electropolished, the microscopic high points of the surface are removed at a faster rate. Sometimes referred to as “surface leveling,” electropolishing smooths part surfaces, giving food particles and bacteria less places to harbor or stick to.

According to research done by the USDA’s ARS (Agricultural Research Service), electropolished surfaces perform better up against mechanically polished surfaces in terms of bacterial biofilm buildup in theory because of the electrochemical nature of the electropolishing process and the fact that bacteria are negatively charged. Electropolishing to a smoother surface ensures that there is less build-up in the first place and the products are easier to wipe down and quicker to clean at the end of the day.

Among many other finishing Treatments -electropolishing has proven to be the most effective in preventing harmful contaminants from forming on products’ surfaces

At the same time electropolishing enhances the chromium to iron ratio on the surface and restores the passive layer which makes the stainless standup longer to corrosive conditions. It’s no wonder many food service equipment manufacturers use electropolishing as a final finishing step in their process.

FOOD PROCESSING AND PACKAGING : Food processing and packaging parts must be highly sanitary for the applications in which they’re used

THE BENEFITS FROM ELECTROPOLISHING

INCREASED CORROSION RESISTANCE

REDUCED BUILDUP OF BACTERIAL BIOFILMS

Before and After

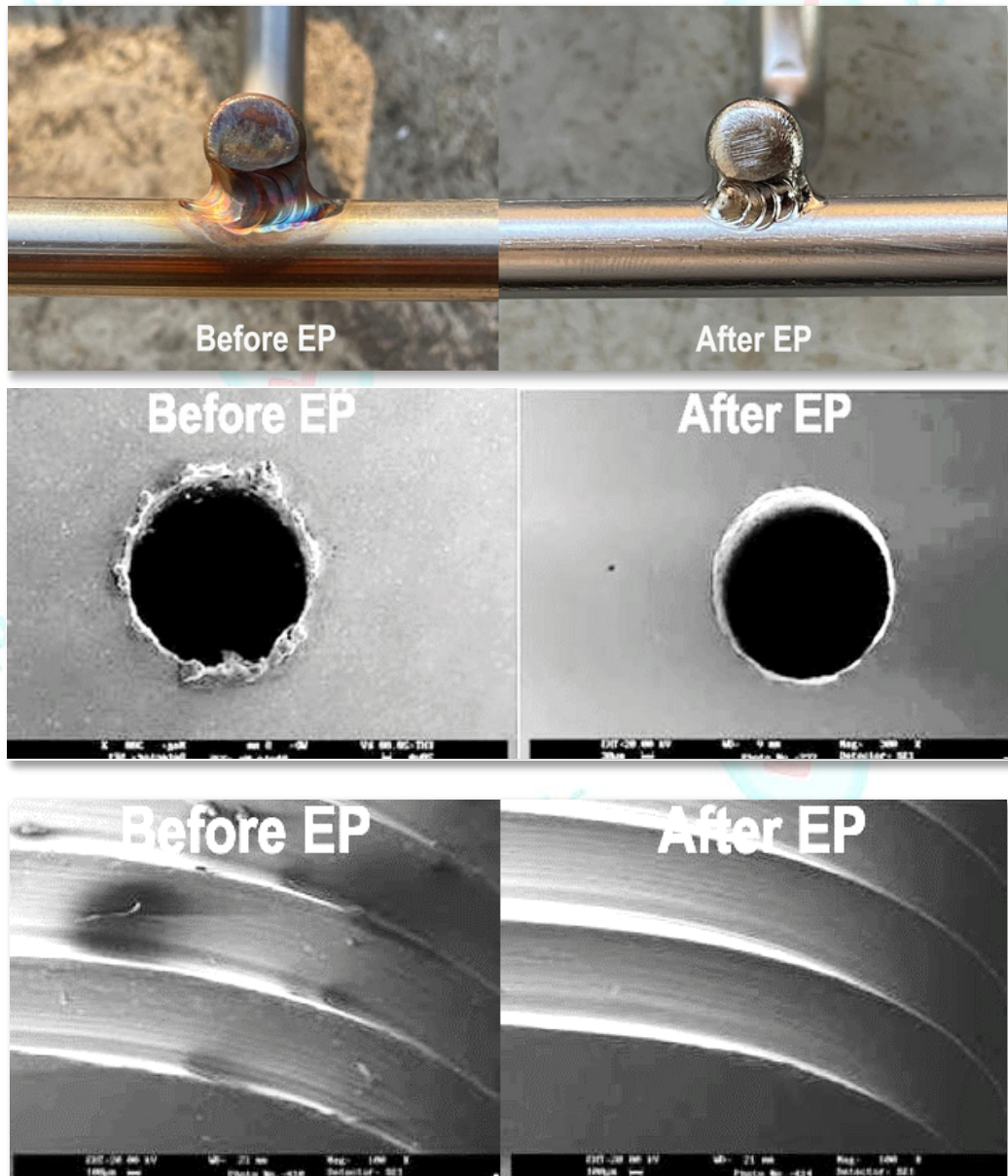

**Hygienic
Design**

“ DURATRAY choose electropolishing as a final finishing step in our process for HYGIENIC area “



CERTIFICATE OF COMPLIANCE

Certificate Number: E536978
 Report Reference: E536978-20230919
 Issue Date: 2023-OCTOBER-13

Issued to: DURATRAY CO., LTD.
 24/19 Moo 7 Lampho Bangbuaithong,
 NONTHABURI 11110, THAILAND

This certificate confirms that representative samples of CABLE TRAYS, METAL. See Addendum page for Models. Have been evaluated by UL in accordance with the Standard(s) indicated on this Certificate.

Standard(s) for Safety: NEMA VE 1-2017 - CABLE TRAY SYSTEMS, NFPA 70, Sections 392.90(A) & 392.60(B) - National Electrical Code

Additional Information: See UL Product iQ® at <https://iq.ulprospector.com> for additional information.

This Certificate of Compliance indicates that representative samples of the product described in the certification report have met the requirements for UL certification. It does not provide authorization to apply the UL Mark. Only the Authorization Page that references the Follow-Up Services Procedure for ongoing surveillance provides authorization to apply the UL Mark.

Only those products bearing the UL Mark should be considered as being UL Certified and covered under UL's Follow-Up Services.

Look for the UL Certification Mark on the product.

 Page 1 of 2





REGISTRARS
Quality Assurance
ISO 9001



UKAS
MANAGEMENT
SYSTEMS

229

 Excellent Center of Welding Technology
 College of Industrial Technology, King Mongkut's University of Technology North Bangkok
 610 Piboonkongsri Rd., Bangkok, Bangkok 10800, THAILAND - Tel: 04620-2910-2900 ext. 4417
 

Certificate Report No. T-ECW 0022017

This letter is to certify that Excellent Center of Welding Technology College of Industrial Technology King Mongkut's University of Technology North Bangkok. Has tested the load tests for AQUANAUTIC LIGHTING & EQUIPMENT CO.,LTD. in order to assure the Maximum Deflection of "DURATRAY" Cable Basket according to NEMA VE1 standards. The test identified in the associated report No. T-ECW date : 6th February 2013 and the Report No. T-ECW date : 22nd July 2015.

Tuesday, March 14th, 2017

 Approved by: 
 Head of Excellent Center of Welding Technology
 College of Industrial Technology

Certificate of Registration 

Certificate Number: **THA1304653786787**

The Management System of **AQUANAUTIC LIGHTING & EQUIPMENT CO., LTD.**

of **24/19 Moo 7, Kanjanapisek Road, Lampho, Bangbuaithong, Nonthaburi, 11110, Thailand**

has been Accessed and Certified as meeting the requirement of **ISO 9001:2015**

Scope of registration
Manufacturer of wire mesh cable basket, connectors and fittings.

Date of Initial Assessment: 19/07/2022
 Date of Registration: 27/07/2022
 Date Re-issued: N/A
 Date of Expiry: 27/07/2025

Authorized by: 
 on behalf of ACS Registrars Ltd

While all due care was exercised in carrying out this assessment, ACS Registrars Ltd accepts responsibility only for proven gross negligence. This certificate remains the property of ACS Registrars Ltd, to whom it must be returned upon request. Certificate validity may be verified upon request.

ACS Registrars Ltd
 333 Moo 9 11th Floor A.P.Nakorn Tower
 Srinakharin Rd.
 Bangna Bangkok
 10260 Thailand
 Tel + (662) 3 222 272
 Fax + (662) 3 222 273
 www.acsregistrars-thai.com

IEC

61537

 Excellent Center of Welding Technology
 College of Industrial Technology, King Mongkut's University of Technology North Bangkok
 610 Piboonkongsri Rd., Bangkok, Bangkok 10800, THAILAND - Tel: 04620-2910-2900 ext. 4417
 

Certificate Report No. T-ECW 0012021

This letter is to certify that Excellent Center of Welding Technology College of Industrial Technology King Mongkut's University of Technology North Bangkok. Has tested the deflection shall not exceed 1/100 of span for AQUANAUTIC LIGHTING & EQUIPMENT CO.,LTD. in order to assure the Maximum Deflection of "DURATRAY" Cable Basket according to IEC 61537 International standards. The test identified in the associated report No. T-ECW 001 to T-ECW 0028 date : 11th April, 2023

Wednesday, April 19th, 2023

 Issued by: 
 Head of Excellent Center of Welding Technology
 College of Industrial Technology

Design experiment

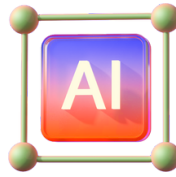

TENSILE TEST



↓	C1	C2	C3	C4	C5	C6	C7	Tensile Test
	StdOrder	RunOrder	CenterPt	Blocks	F (lb)	I (a)	T (s)	
1	22	1	0	2	915	5450	14	2951.09
2	14	2	1	2	580	6000	5	2948.43
3	18	3	1	2	580	6000	23	2949.76
4	20	4	0	2	915	5450	14	2951.21
5	21	5	0	2	915	5450	14	2949.33
6	12	6	1	2	580	4900	5	2950.05
7	17	7	1	2	1250	4900	23	2950.47
8	15	8	1	2	1250	6000	5	2949.76
9	13	9	1	2	1250	4900	5	2949.67
10	16	10	1	2	580	4900	23	2948.80
11	19	11	1	2	1250	6000	23	2949.91
12	26	12	1	3	1250	6000	5	2950.23
13	28	13	1	3	1250	4900	23	2950.99
14	25	14	1	3	580	6000	5	2950.55
15	30	15	1	3	1250	6000	23	2950.27
16	29	16	1	3	580	6000	23	2950.39
17	23	17	1	3	580	4900	5	2947.65
18	24	18	1	3	1250	4900	5	2950.49
19	33	19	0	3	915	5450	14	2951.47
20	32	20	0	3	915	5450	14	2949.17

Fit Linear Model for Tensile Test
Effects Report

Interaction Plots for Tensile Test

Describes how the mean of Tensile Test changes if you change the settings of two factors.

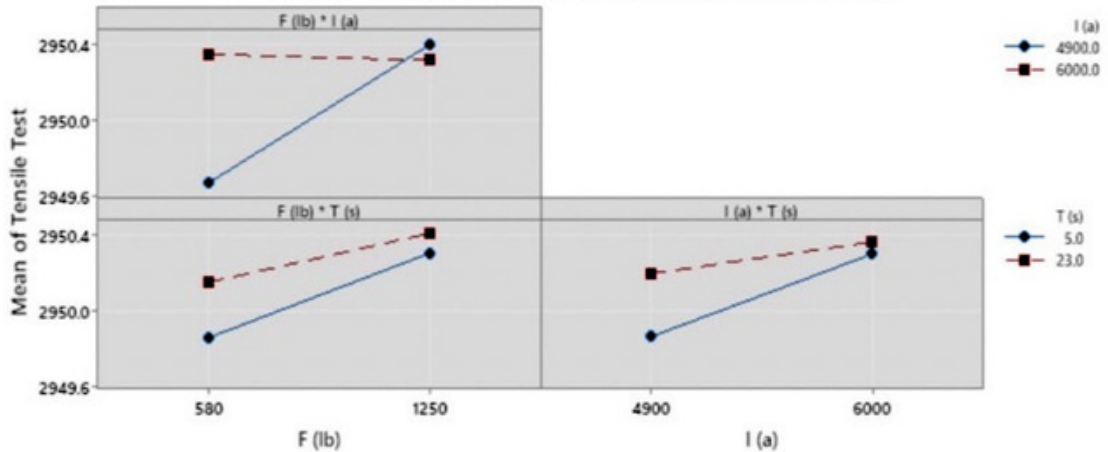

Main Effects Plots for Tensile Test

Describes how changes to a single factor affect the mean of Tensile Test.

If there is an interaction between factors, use the interaction plots to determine the optimal factor settings.

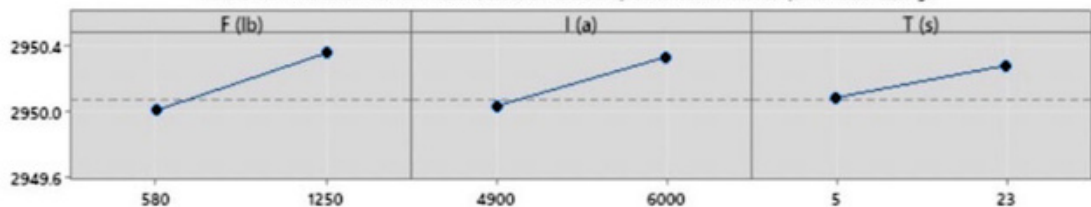

A gray background represents a term that was removed from the model because it is not statistically significant.



DURATRAY
cable basket



VT5 / SVT5 : Cable Basket for Heavy Duty

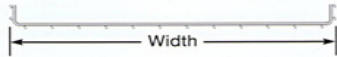
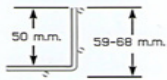
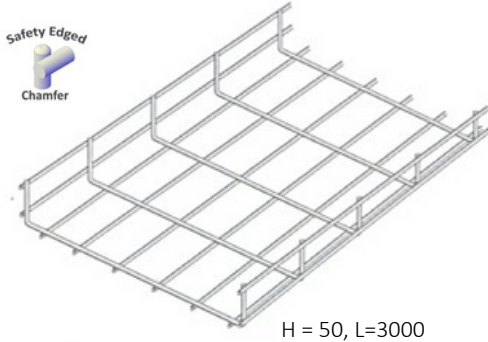

Part No.	Width (mm.)	Ø Wire (mm.)	Part No.	Width (mm.)	Ø Wire (mm.)
VT505	50	6	SVT565	650	9
VT510	100	6	SVT570	700	9
VT515	150	6	SVT575	750	9
VT520	200	6	SVT580	800	9
VT525	250	6	SVT585	850	9
VT530	300	6	SVT590	900	9
VT535	350	6	SVT595	950	9
VT540	400	6	SVT5100	1000	9
VT545	450	6	SVT5105	1050	9
VT550	500	6	SVT5110	1100	9
VT555	550	6	SVT5115	1150	9
VT560	600	6	SVT5120	1200	9



Approved by



Nestlé Global

VT5 : Standard Type

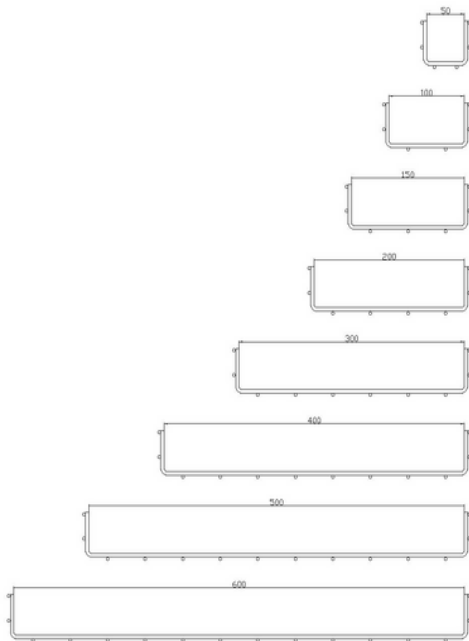

Part No.	Width (mm.)	Ø Wire (mm.)
VT505	50	4 / 4.5 / 5 / 6
VT510	100	4 / 4.5 / 5 / 6
VT515	150	4 / 4.5 / 5 / 6
VT520	200	4 / 4.5 / 5 / 6
VT525	250	4.5 / 5 / 6
VT530	300	5 / 6
VT535	350	5 / 6
VT540	400	5 / 6
VT545	450	6
VT550	500	6
VT555	550	6
VT560	600	6



VT10 / SVT10 : Cable Basket for Heavy Duty

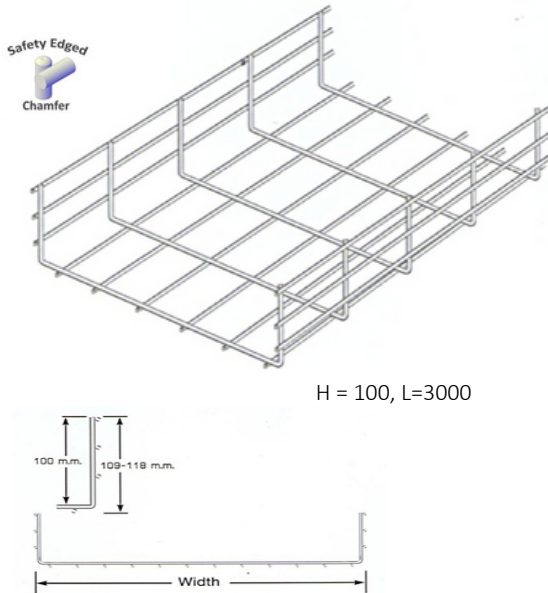

Part No.	Width (mm.)	Ø Wire (mm.)	Part No.	Width (mm.)	Ø Wire (mm.)
VT1005	50	6	SVT1065	650	9
VT1010	100	6	SVT1070	700	9
VT1015	150	6	SVT1075	750	9
VT1020	200	6	SVT1080	800	9
VT1025	250	6	SVT1085	850	9
VT1030	300	6	SVT1090	900	9
VT1035	350	6	SVT1095	950	9
VT1040	400	6	SVT10100	1000	9
VT1045	450	6	SVT10105	1050	9
VT1050	500	6	SVT10110	1100	9
VT1055	550	6	SVT10115	1150	9
VT1060	600	6	SVT10120	1200	9



Approved by Nestlé Global

VT10 : Standard Type

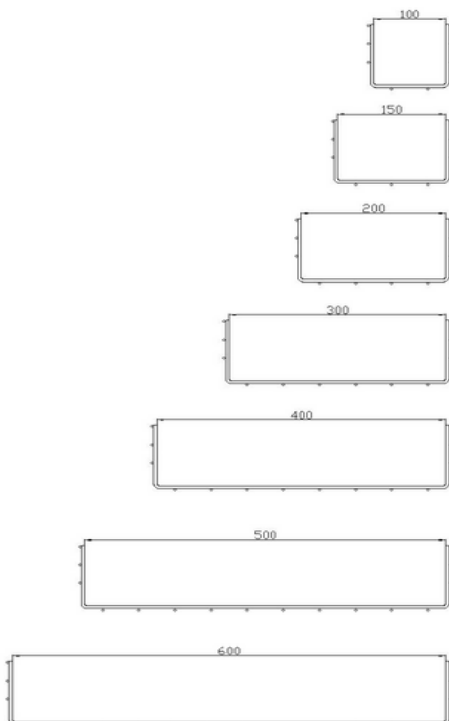

Part No.	Width (mm.)	Ø Wire (mm.)
VT1005	50	4 / 4.5 / 5 / 6
VT1010	100	4 / 4.5 / 5 / 6
VT1015	150	4 / 4.5 / 5 / 6
VT1020	200	4 / 4.5 / 5 / 6
VT1025	250	4.5 / 5 / 6
VT1030	300	4.5 / 5 / 6
VT1035	350	5 / 6
VT1040	400	5 / 6
VT1045	450	6
VT1050	500	6
VT1055	550	6
VT1060	600	6



VT15 / SVT15 : Cable Basket for Heavy Duty

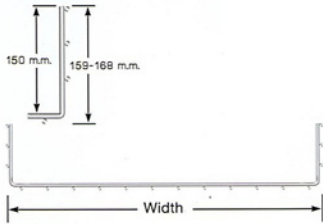
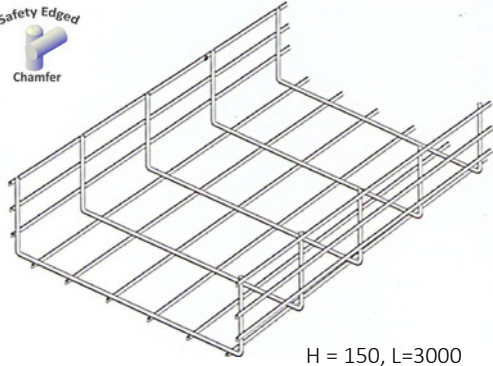

Part No.	Width (mm.)	Ø Wire (mm.)	Part No.	Width (mm.)	Ø Wire (mm.)
VT1520	200	6	SVT1565	650	9
VT1525	250	6	SVT1570	700	9
VT1530	300	6	SVT1575	750	9
VT1535	350	6	SVT1580	800	9
VT1540	400	6	SVT1585	850	9
VT1545	450	6	SVT1590	900	9
VT1550	500	6	SVT1595	950	9
VT1555	550	6	SVT15100	1000	9
VT1560	600	6	SVT15105	1050	9
			SVT15110	1100	9
			SVT15115	1150	9
			SVT15120	1200	9



VT15 : Standard Type

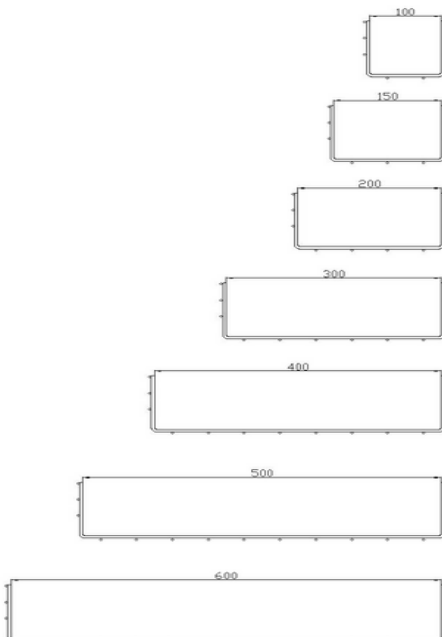

Part No.	Width (mm.)	Ø Wire (mm.)
VT1520	200	4.5 / 5 / 6
VT1525	250	4.5 / 5 / 6
VT1530	300	4.5 / 5 / 6
VT1535	350	5 / 6
VT1540	400	5 / 6
VT1545	450	6
VT1550	500	6
VT1555	550	6
VT1560	600	6



NEMA VE1 (SUS304/316)

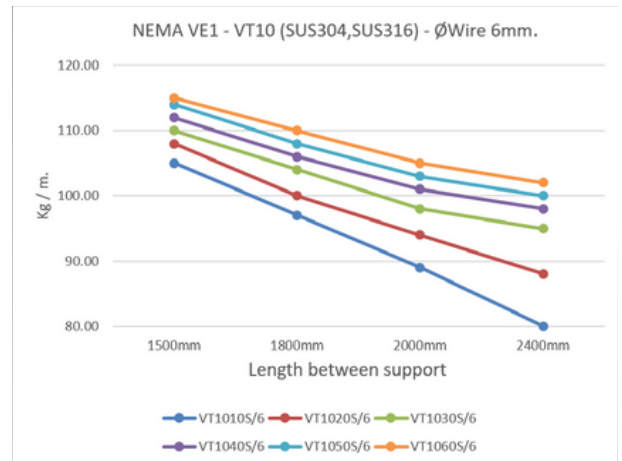
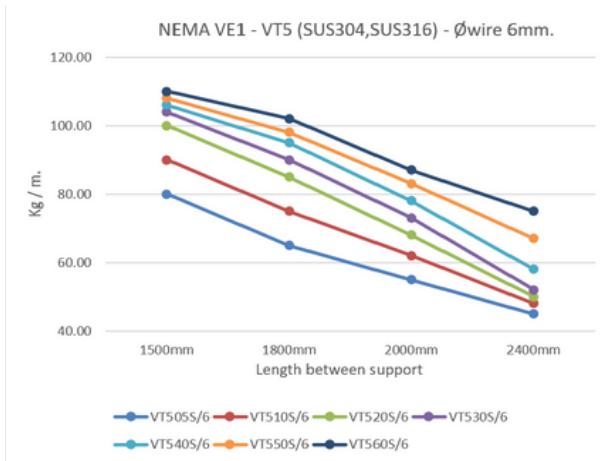
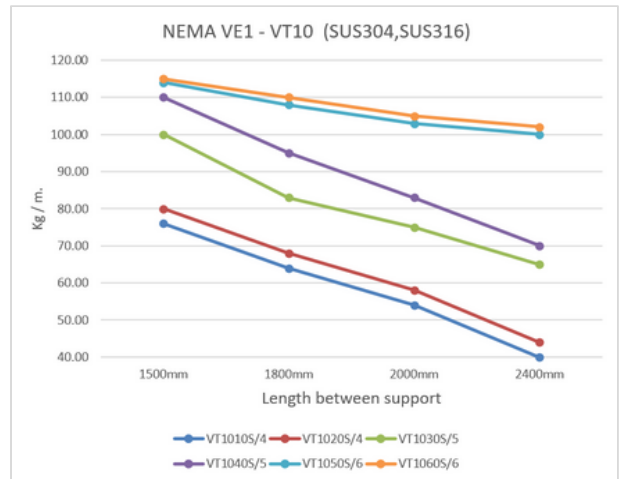
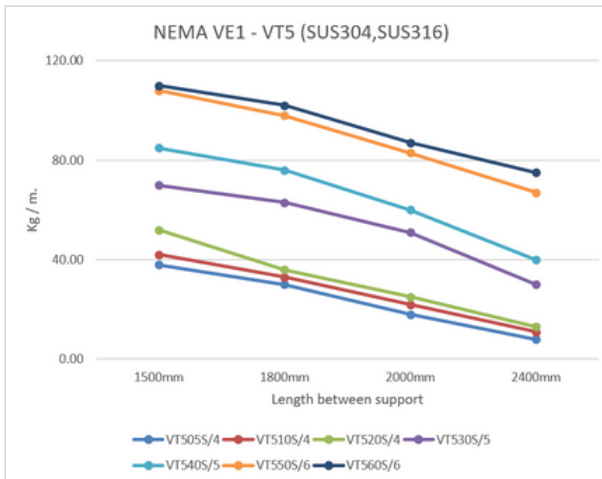

NEMA VE1 (EZ, HDG, PC)

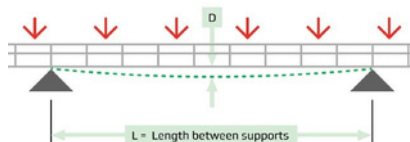
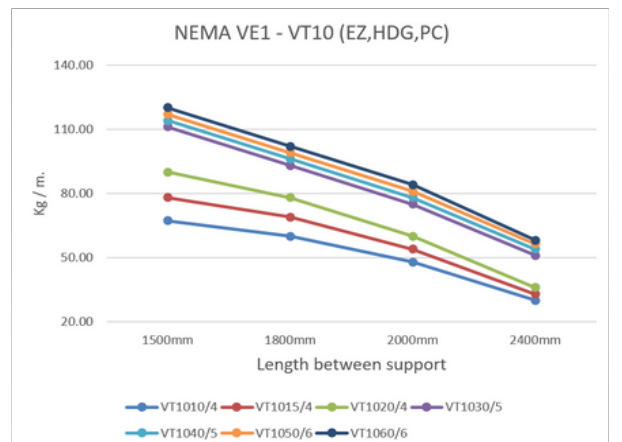
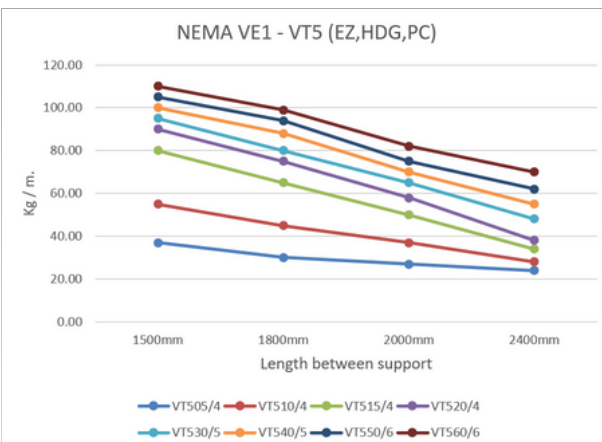



DURATRAY

Fittings

VI : VERTICAL INSIDE



Part No.	Width (mm.)	Ø Wire (mm.)
VI	50 -600	4 / 4.5 / 5 / 6
SVI	700 -1200	9

- 304
- 304L
- 316
- EZ
- HDG
- PC



Approved by Nestlé Global

VO : VERTICAL OUTSIDE



Part No.	Width (mm.)	Ø Wire (mm.)
VO	50 -600	4 / 4.5 / 5 / 6
SVO	700 -1200	9

- 304
- 304L
- 316
- EZ
- HDG
- PC



Approved by Nestlé Global

TE : TEE WAY

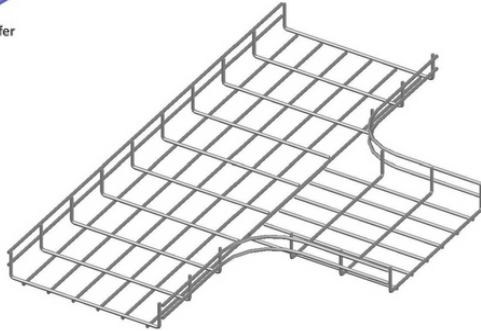

Part No.	Width (mm.)	Ø Wire (mm.)
TE	50 -600	4 / 4.5 / 5 / 6
STE	700 -1200	9

- 304
- 304L
- 316
- EZ
- HDG
- PC



CR : CROSS

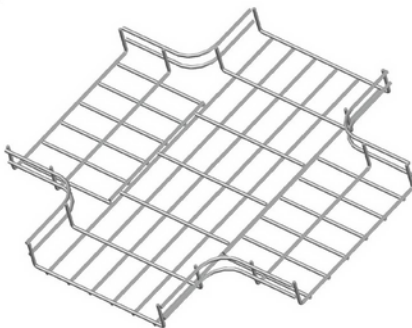

Part No.	Width (mm.)	Ø Wire (mm.)
CR	50 -600	4 / 4.5 / 5 / 6
SCR	700 -1200	9

- 304
- 304L
- 316
- EZ
- HDG
- PC



RA : RADIUS ELBOW

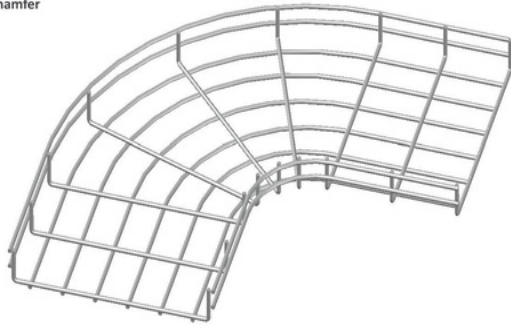

Part No.	Width (mm.)	Ø Wire (mm.)
RA	50 -600	4 / 4.5 / 5 / 6
SRA	700 -1200	9

- 304
- 304L
- 316
- EZ
- HDG
- PC



EL : 90° ELBOW

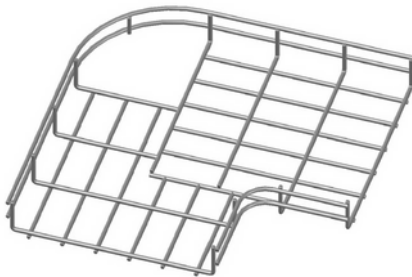

Part No.	Width (mm.)	Ø Wire (mm.)
EL	50 -600	4 / 4.5 / 5 / 6
SEL	700 -1200	9

- 304
- 304L
- 316
- EZ
- HDG
- PC



HR : HORIZONTAL REDUCE

Safety Edged
Chamfer

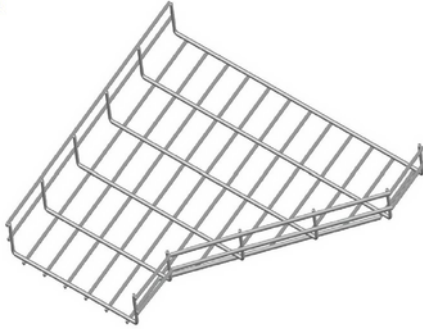

Hygienic
Design

EP Electro
Polishing

Part No.	Width (mm.)	Ø Wire (mm.)
HR	50 -600	4 / 4.5 / 5 / 6
SHR	700 -1200	9

304 304L 316 EZ HDG PC



Approved by  Nestlé Global

Made to Order Fittings

Fittings can be made as customer requirement

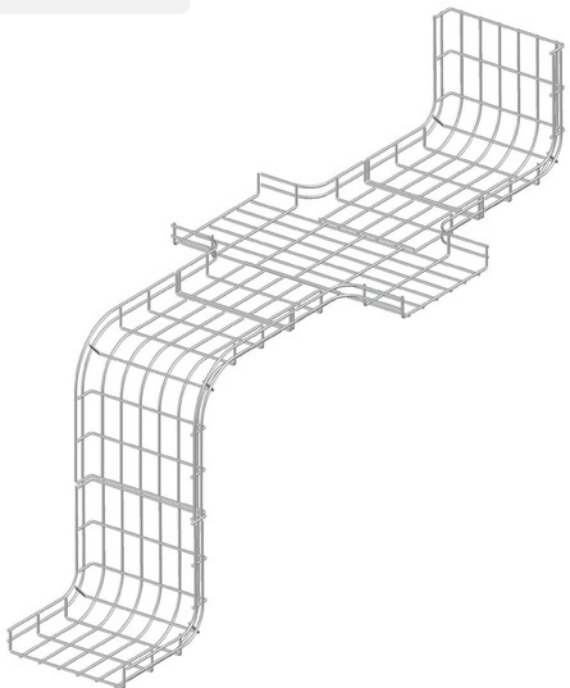
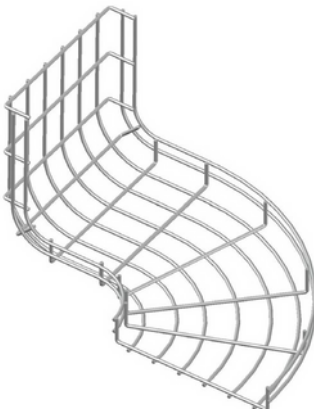



DURATRAY

Support

SD50 / SD100 : SUPPORT

For Horizontal Installation

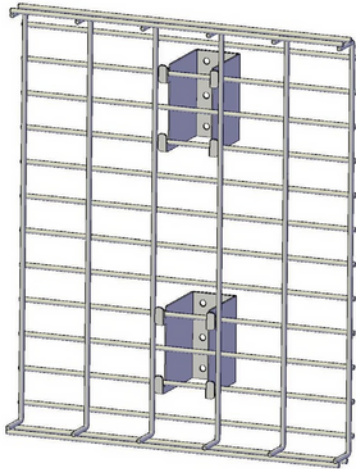
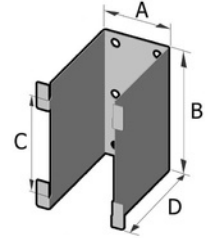
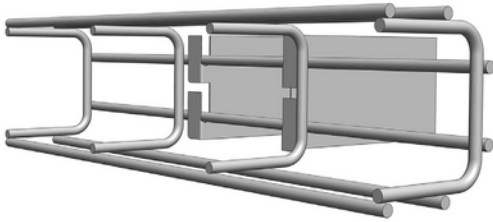

Part No.	D (mm.)	C (mm.)	FL KgF
SD50/30	50	30	260
SD50/50	50	50	320
SD50/100	50	100	400
SD100/30	100	30	135
SD100/50	100	50	200
SD100/100	100	100	320



Installation amount per cable basket 3000mm.

Part No.	50	100	200-300	400-500	600
SD50/30	2				
SD50/50		2	4	4	6
SD50/100		2	4	4	6
SD100/30	2				
SD100/50		2	4	4	6
SD100/100			4	4	6

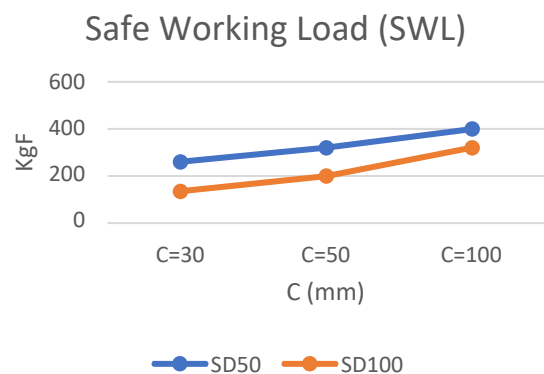

SDL50 / SDL100 : SUPPORT FOR SVT

For Horizontal Installation

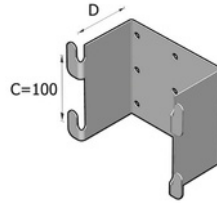
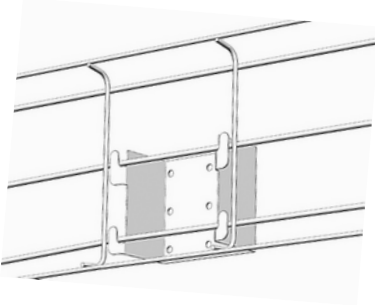

Part No.	D (mm.)	C(mm.)	\downarrow F kgf
SDL50/100	50	100	400
SDL50/200	50	200	480
SDL100/100	100	100	360
SDL100/200	100	200	400

Remark : For SVT Model Only (Ø 9mm.)

For Vertical Installation

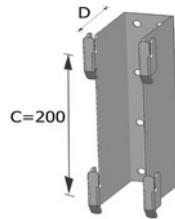
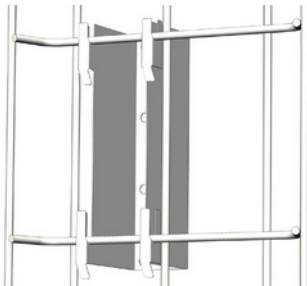

Approved by Nestlé Global

Part No.	Installation amount per cable basket 3000mm.			Safe Working Load (SWL)
	700-800	900-1000	1100-1200	
SDL50/100	4	4	6	
SDL50/200	4	4	6	
SDL100/100	4	4	6	
SDL100/200	4	4	6	

SDS50 / SDS100 : SUPPORT

For Vertical Installation

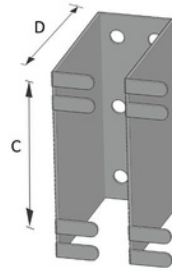

Part No.	D (mm.)	C (mm.)	For Cable Basket size	↓ F ↓ kgf
SDS50/100	50	100	100-600	270
SDS100/100	100	100	100-600	200

- 304
- 316
- EZ
- HDG



Approved by Nestlé Global

Installation amount per cable basket 3000mm.

Part No.	100	200-500	600
SDS50/100	2	4	6
SDS50/200	2	4	6
SDS100/100		4	6
SDS100/200		4	6

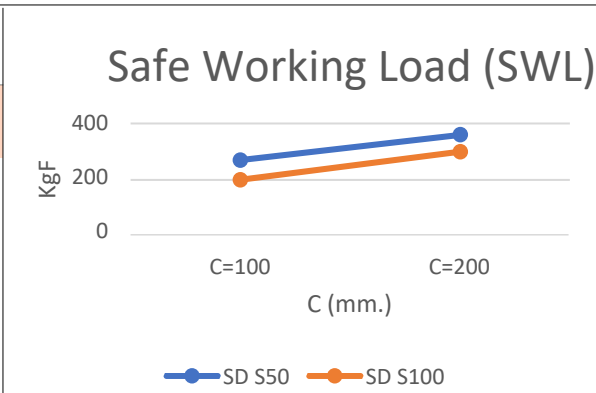

SDA50 / SDA100 : SUPPORT

For Vertical Installation

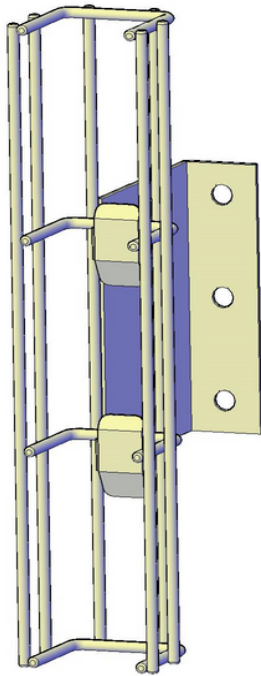

Part No.	D (mm.)	C (mm.)	For Cable Basket size	F_{ket}
SDA50/100	50	100	50	144
SDA100/100	100	100	50	108

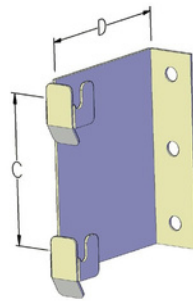

- 304
- 316
- EZ
- HDG



Approved by Nestlé Global

M50 / M100 : SUPPORT

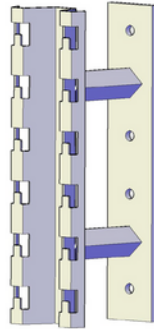
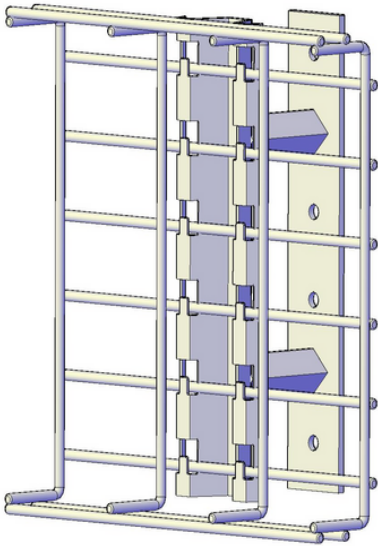

Part No.	Height (mm.)	For Cable Basket size (mm.)
M50/50-600	50	100-600
M100/50-600	100	100-600



- 304
- 316
- EZ
- HDG



Approved by Nestlé Global

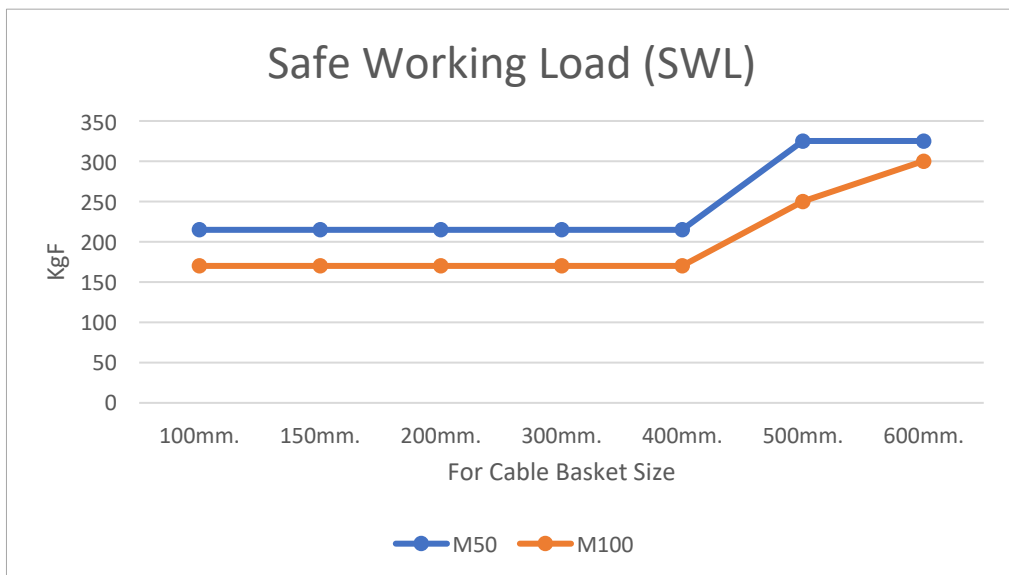

M SUPPORT

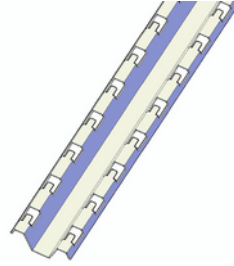
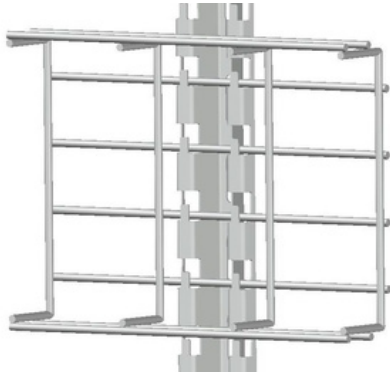

Part No.	For Cable Basket size (mm.)
M100	100
M200	200
M300	300
M400	400
M500	500
M600	600

** Length over 600 will be made as customer request.



Approved by



Nestlé Global

W SUPPORT

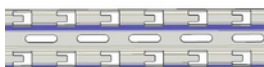
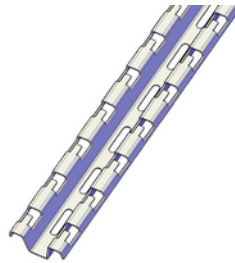
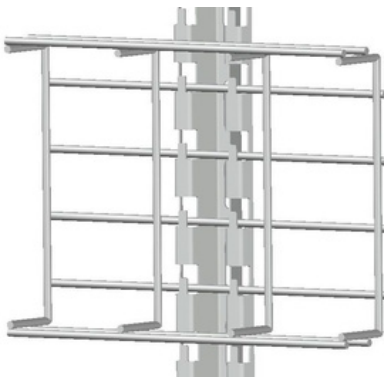

Part No.	For Cable Basket size (mm.)
W100	100
W200	200
W300	300
W400	400
W500	500
W600	600

** Length over 600 will be made as customer request.



Approved by



Nestlé Global

FL50 / FL100 : SUPPORT

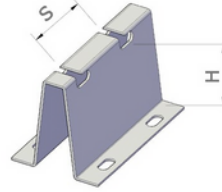
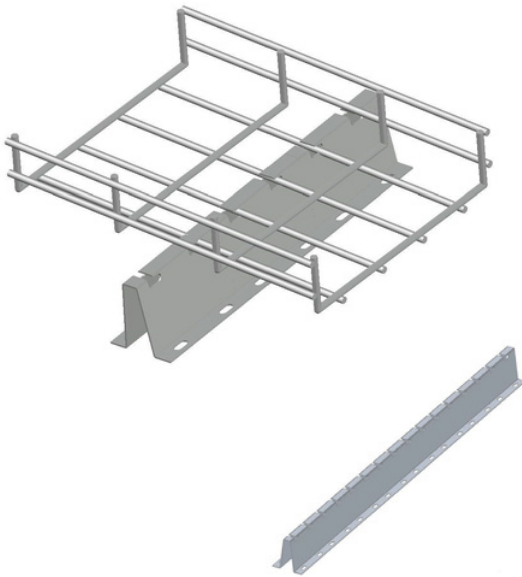

Bend and Lock



Part No.	H(mm.)	S (mm.)
FL50/30	50	30
FL50/50	50	50
FL50/100	50	100
FL100/30	100	30
FL100/50	100	50
FL100/100	100	100

Remark : All others dimension can be made to order

304

316

EZ

HDG



Approved by



Nestlé Global

HGL: SUPPORT

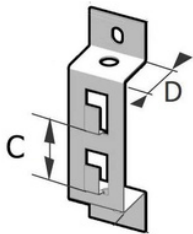
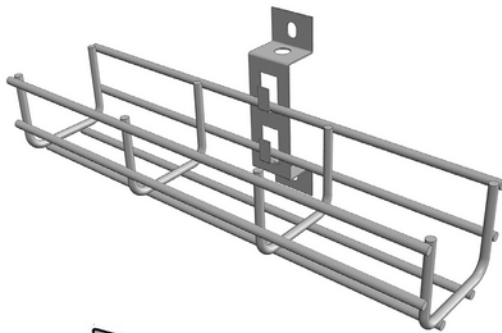

Bend and Lock



Part No.	D (mm.)	C (mm.)
HGL30/30	30	30

304

316

EZ

HDG



Approved by



Nestlé Global

H SUPPORT

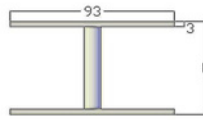
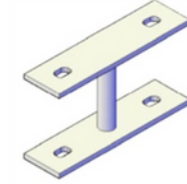
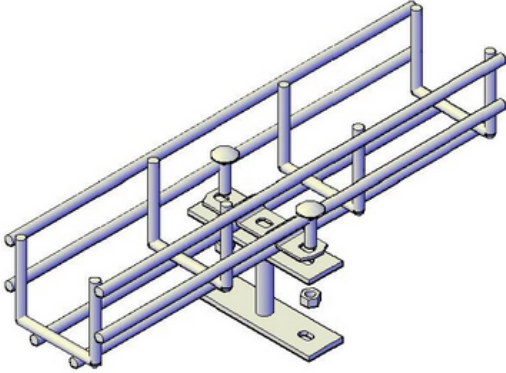

Part No.	L (mm.)
H50	50
H100	100



T SUPPORT

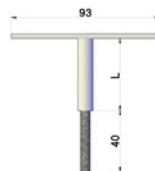
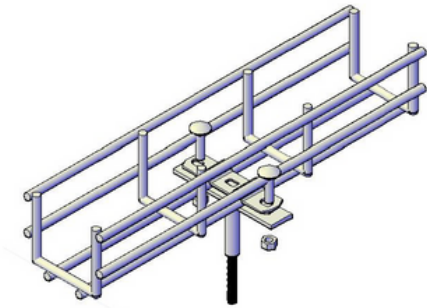

Part No.	L (mm.)
T50	50
T100	100



I SUPPORT

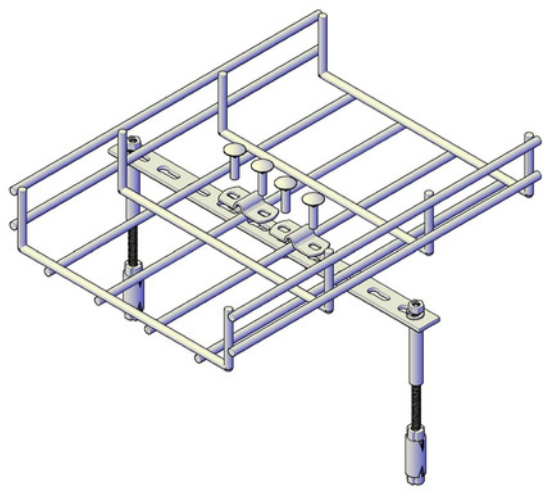

Part No.	L (mm.)
I50	50
I100	100

- 304
- 316
- EZ
- HDG

CL SUPPORT

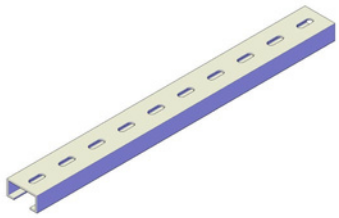
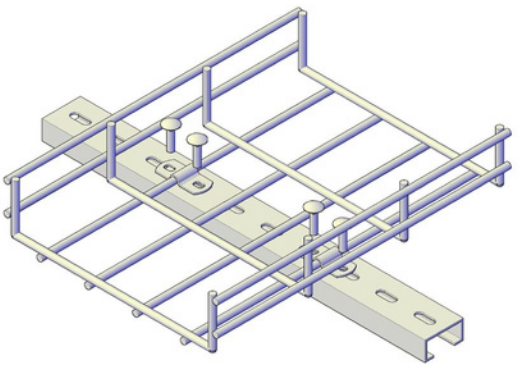

Part No.	L (mm.)
CL	1200

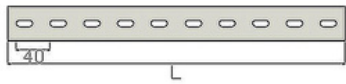
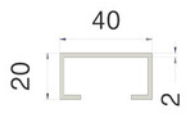

- 304
- 316
- EZ
- HDG

C SUPPORT

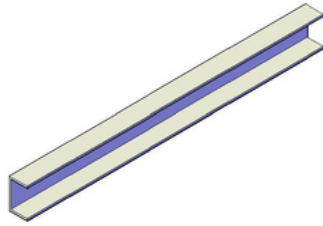
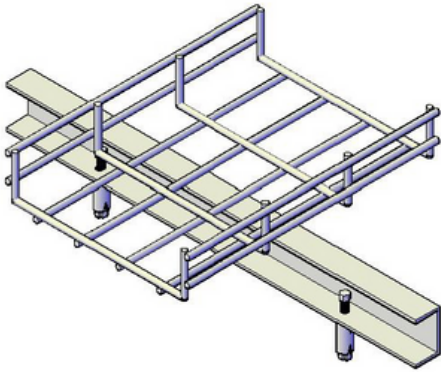

Part No.	L (mm.)
C12	1200
C24	2400



- 304
- 316
- EZ
- HDG

S SUPPORT

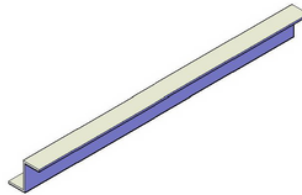
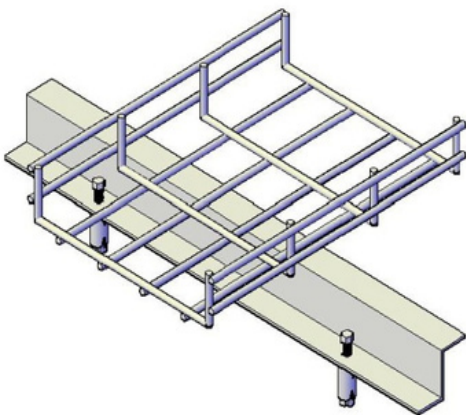

Part No.	L (mm.)
S12	1200
S24	2400

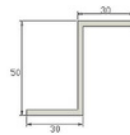

- 304
- 316
- EZ
- HDG

TSL : SUPPORT

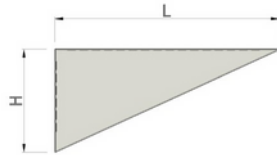
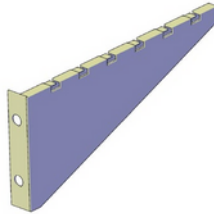
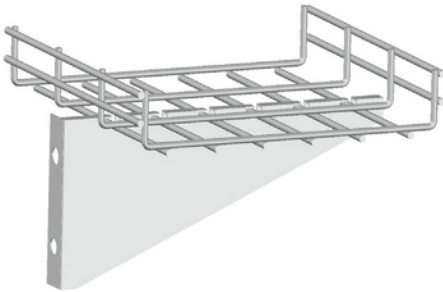

Part No.	For Cable Basket size (mm.)
TSL100	100
TSL200	200
TSL300	300
TSL400	400
TSL500	500
TSL600	600



TS : SUPPORT

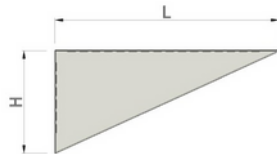
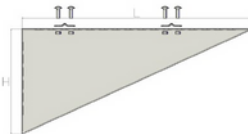
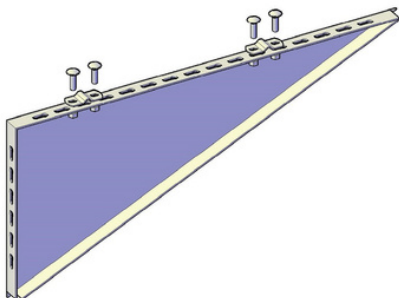

Part No.	For Cable Basket size (mm.)
TS100	100
TS200	200
TS300	300
TS400	400
TS500	500
TS600	600



NEW

SD45 : SD SUPPORT 45°

For Horizontal Installation

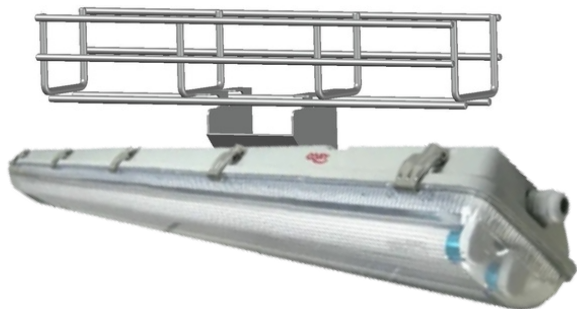

Bend and Lock



Part No

SD45

304

316

EZ



NEW

U SUPPORT

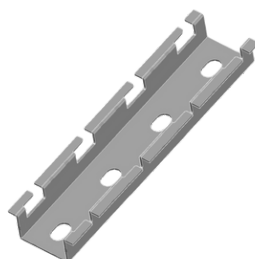
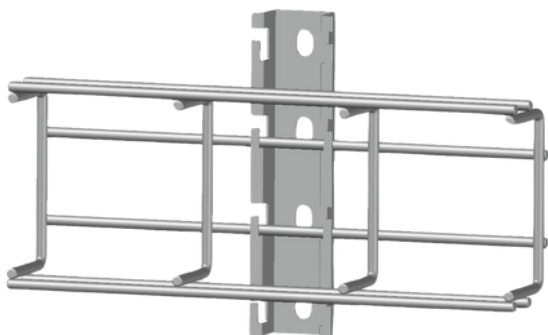

Bend and Lock



Part No.	For Cable Basket size (mm.)
U100	100
U200	200
U300	300
U400	400
U500	500
U600	600

** Length over 600 will be made as customer request.

304

316

EZ

HDG



Approved by Nestlé Global



DURATRAY
accessories



CND : CONNECTOR LOCK

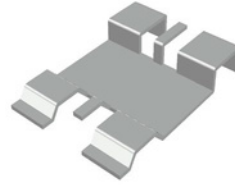
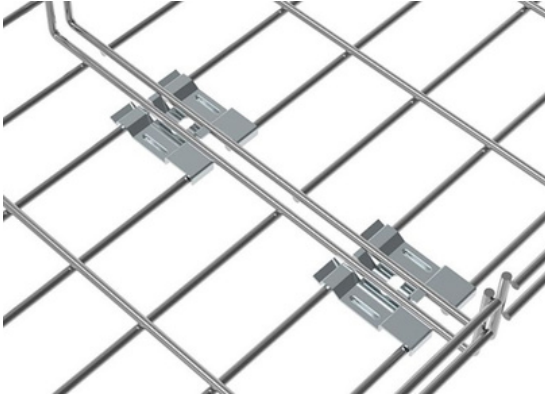

 Hygienic Design

Part No.	
CND50	63

304 316 EZ HDG



Approved by  Nestlé Global

CNK : KLICLOCK CONNECTOR

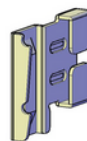
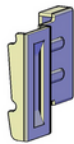
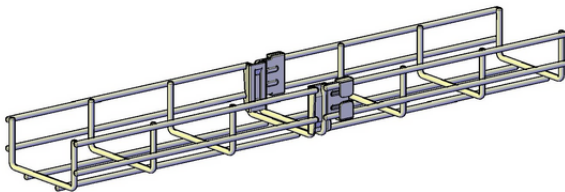
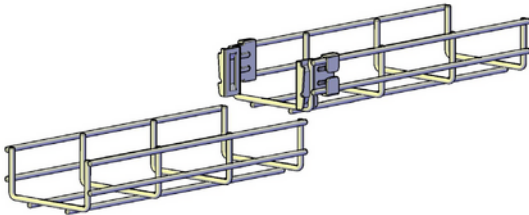

 Hygienic Design

Part No.	For Cable Basket Ø Wire (mm.)	
CNK	4-5	-

304



SPXL : SPLICE PLATE LOCK

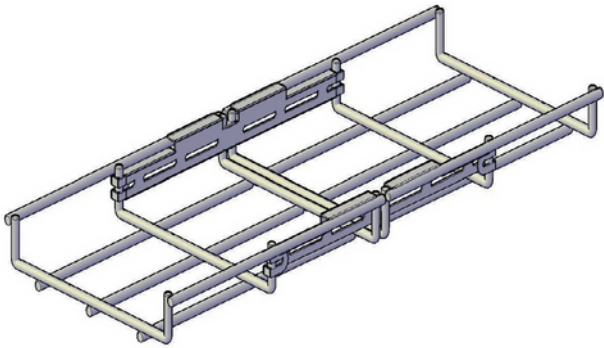

 Hygienic Design

Part No.	For Cable Basket Ø Wire (mm.)	\downarrow FL kgf
SPXL	9	-

Remark : For SVT Model Only (Ø 9mm.)

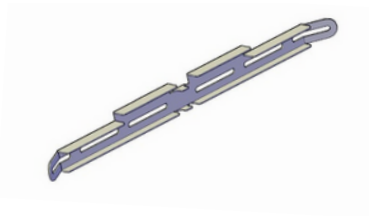

- 304
- 316
- EZ
- HDG



SPL : SPLICE PLATE LOCK

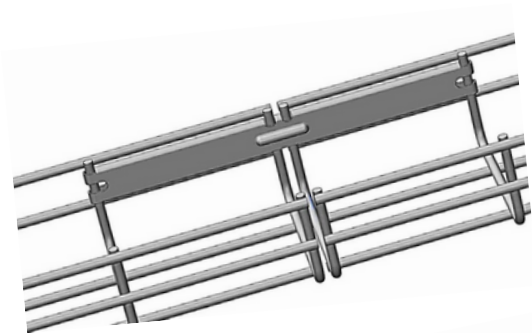

 Hygienic Design

Part No.	For Cable Basket Ø Wire (mm.)	\downarrow FL kgf
SPL	4-6	86

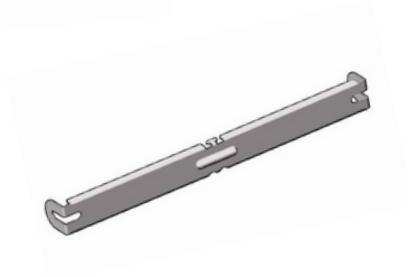

- 304
- 316
- EZ
- HDG



Approved by 

Nestlé Global

SPS : SPLICE PLATE LOCK

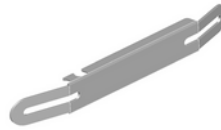
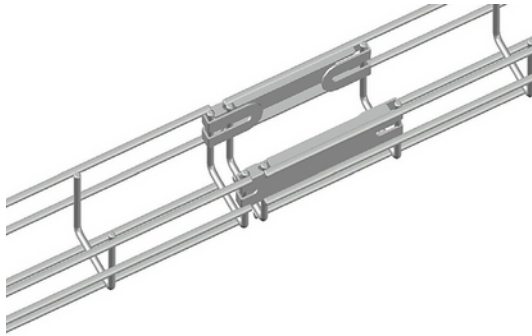

 Hygienic Design

Part No.	For Cable Basket Ø Wire (mm.)	
SPS	4-6	25

304 316 EZ HDG



NEMA
National Electrical Manufacturers Association



Approved by



Nestlé Global

SB : SPLICE BAR

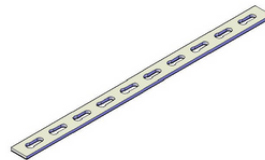
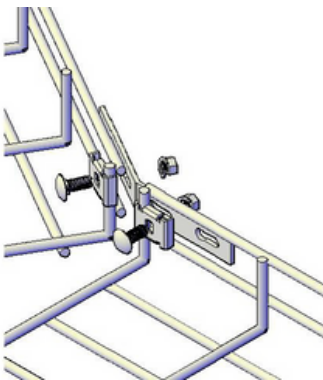

Part No.	L (mm.)
SB30	305
SB60	605
SB120	1205

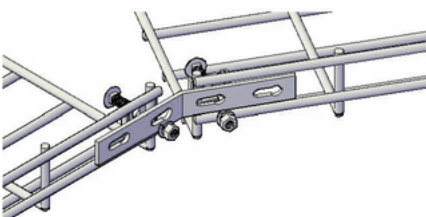

304 316 EZ HDG

CN : CONNECTOR

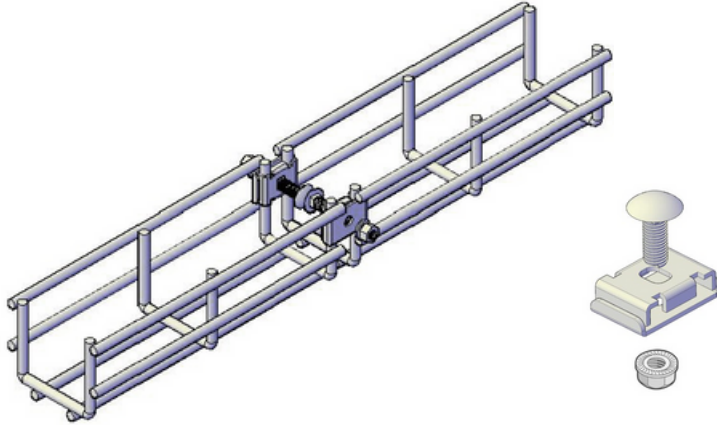

Part No.	For Cable Basket Ø Wire (mm.)
CN	4.5-6

304 316 EZ HDG

CNL : CONNECTOR

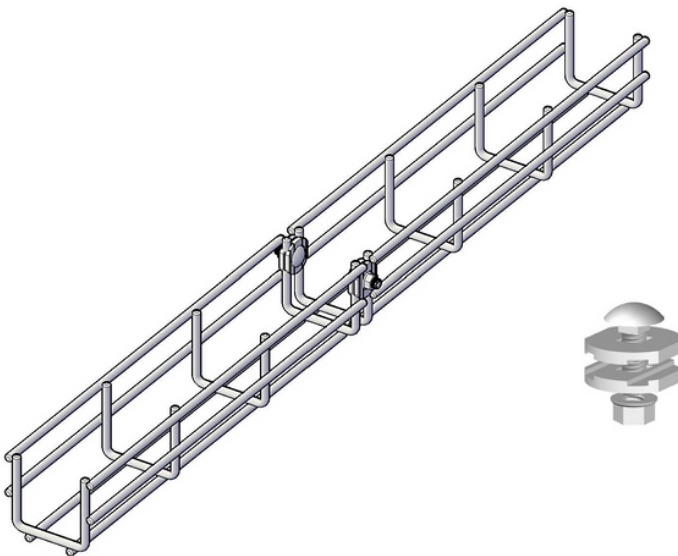

Part No.	For Cable Basket Ø Wire (mm.)
CNL	4-6

304 316 EZ HDG

CS : SINGLE CLAMP

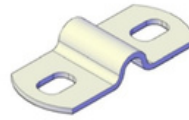
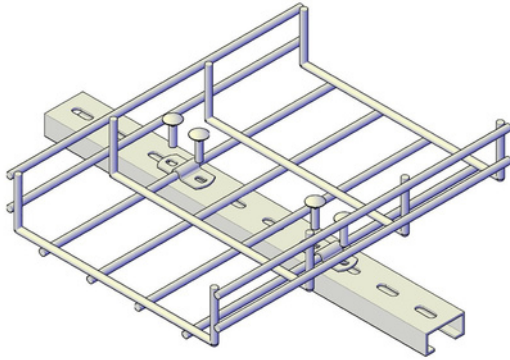

Part No.	For Cable Basket Ø Wire (mm.)
CS-4.5	4.5
CS-6	6
CS-9	9

304 316 EZ HDG

CD : DOUBLE CLAMP

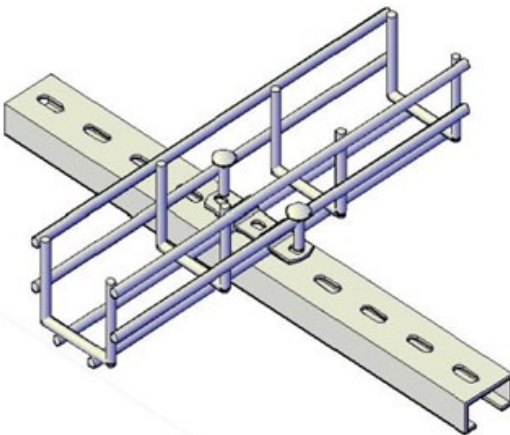

Part No.	For Cable Basket Ø Wire (mm.)
CD-4.5	4.5
CD-6	6

304 316 EZ HDG

CDS : DOUBLE CLAMP SMALL

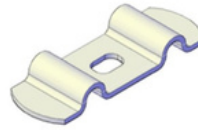
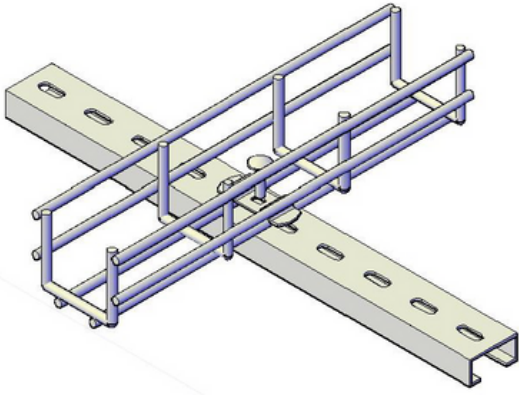

Part No.	For Cable Basket Ø Wire (mm.)
CDS-4.5	4.5

304

316

EZ

HDG

CDM : DOUBLE CLAMP MEDIUM

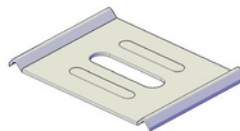
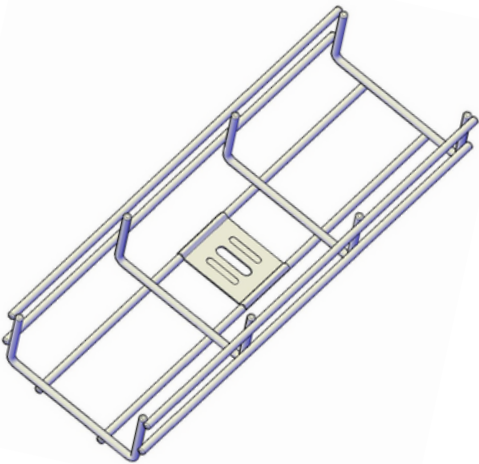

Part No.	For Cable Basket Ø Wire (mm.)
CDM	4-6

304

316

EZ

HDG

CDL : DOUBLE CLAMP LARGE

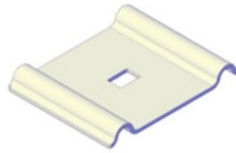
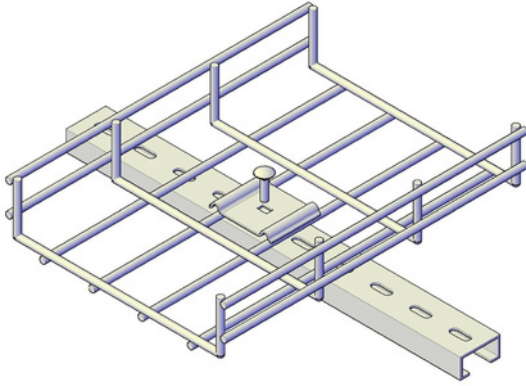

Part No.	For Cable Basket Ø Wire (mm.)
CDL4.5	4.5
CDL6	6

- 304
- 316
- EZ
- HDG

SPT : CURVE SPLITTER

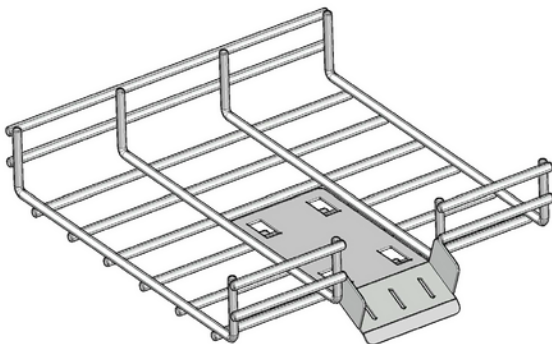

Part No.
SPT

- 304
- 316
- EZ
- HDG



PT : PARTITION

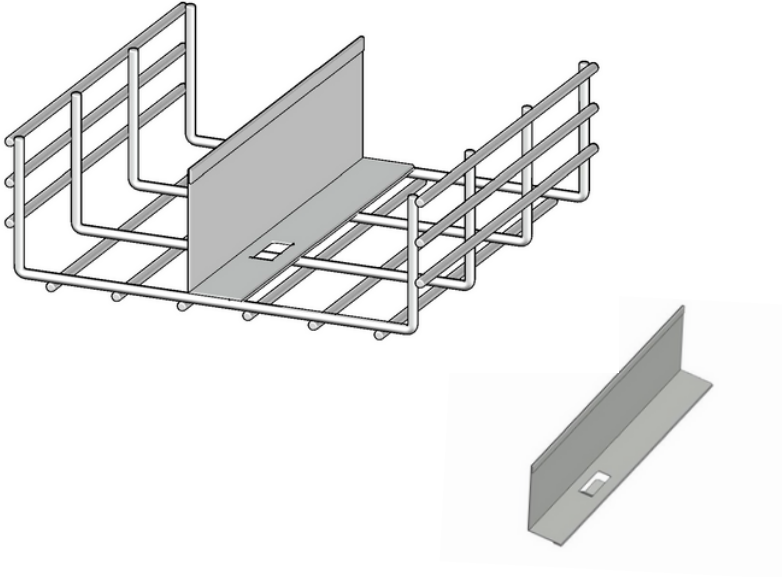

Part No.	For Cable Basket H (mm.)
PT30	25
PT50	50
PT100	100



CV : COVER

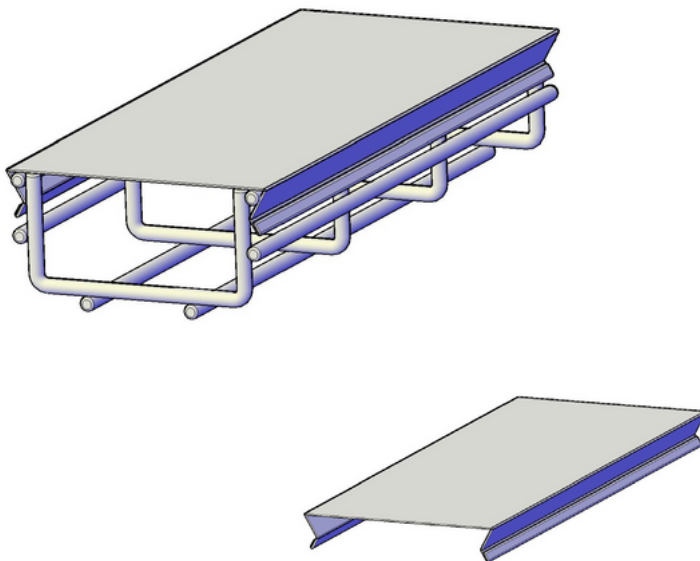

Part No.	For Cable Basket Size (mm.)
CV05	50
CV10	100
CV15	150
CV20	200
CV30	300
CV40	400
CV50	500
CV60	600



CTO : CONDUIT TAKE OFF PLATE

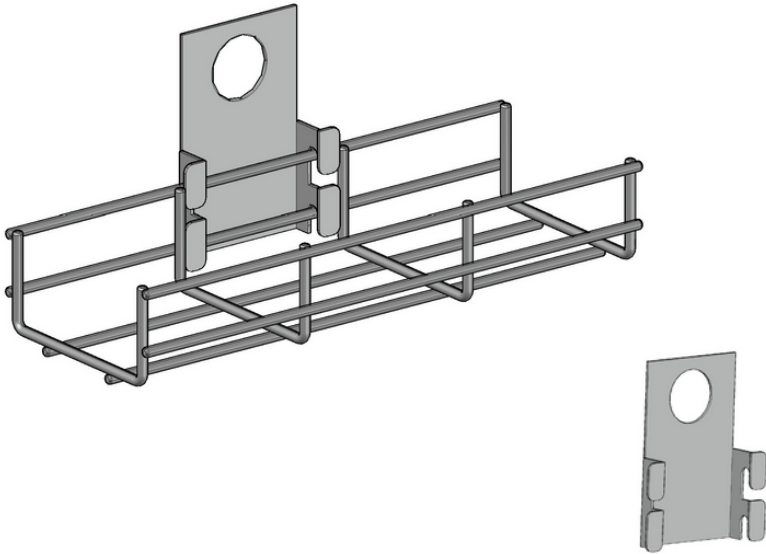

Part No.

CTO

304

316



NEW

EB : COPPER EARTHING BOLT

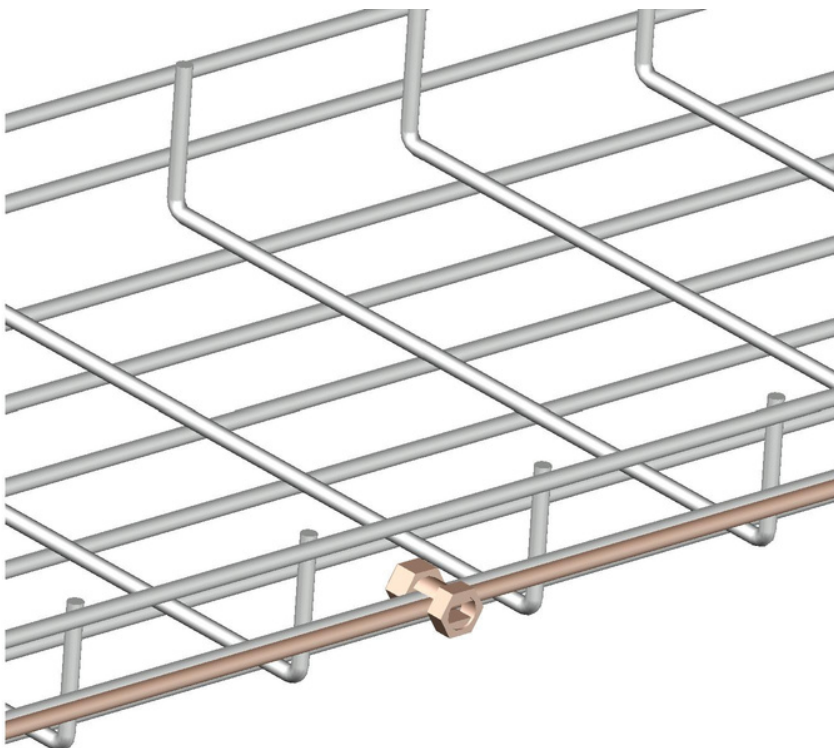

Part No.

For Size (mm.)

EB5

4 - 4.7 mm.

EB6

5 - 7 mm.





DURATRAY

Installation

DURATRAY Cable Basket Systems

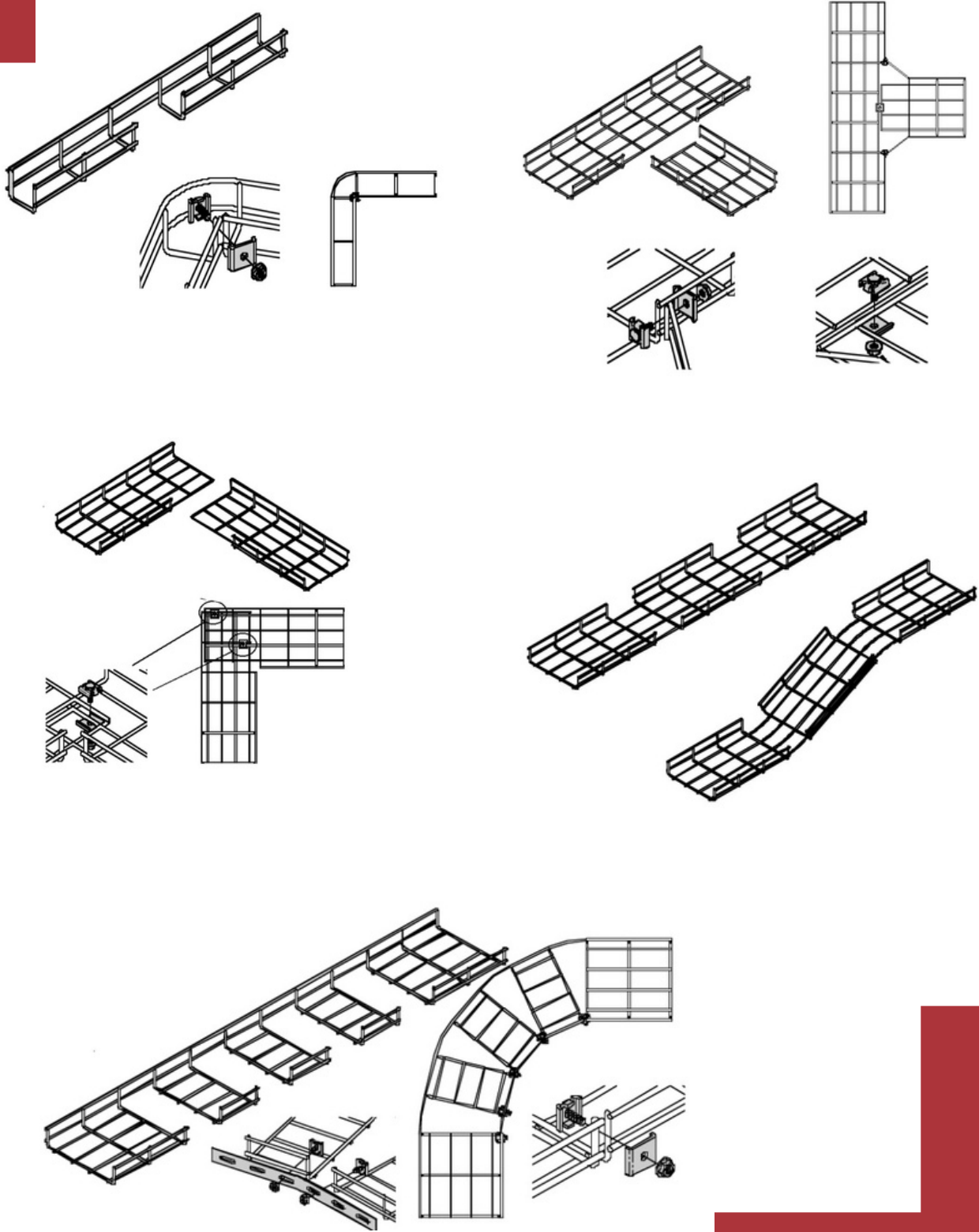

DURATRAY Cable Basket Systems

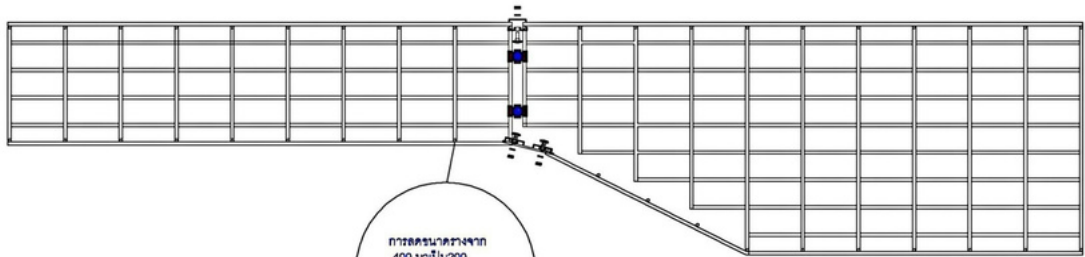

การต่อแนวจาก
400 มม. เป็น 200
มม. ใช้ Connector 4 ตัว
ในกรณีตรงแนวเท่านั้น

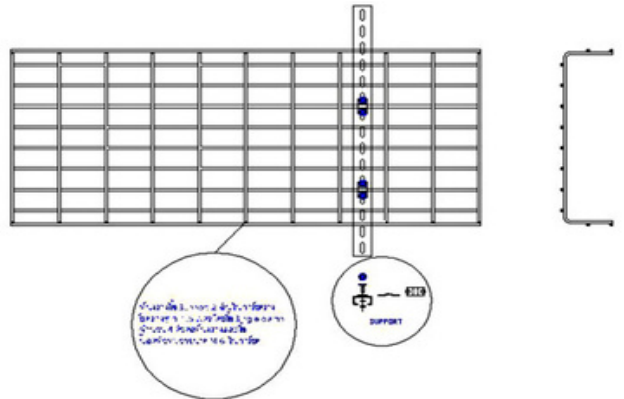
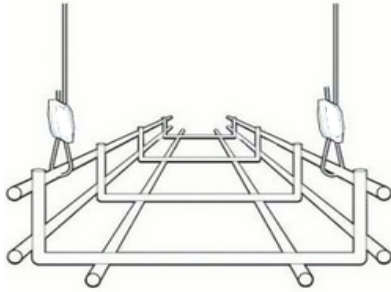

การต่อแนวจาก 200 มม. เป็น 400 มม.
ใช้ Connector 2 ตัว ในกรณีตรงแนวเท่านั้น
ใช้ Connector 4 ตัว ในกรณีตรงแนวเท่านั้น

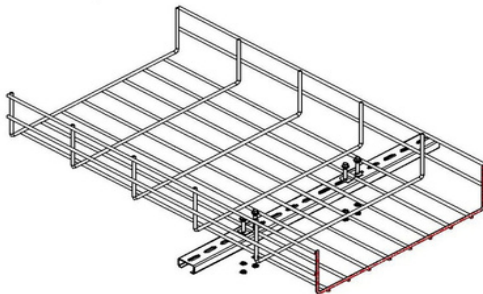
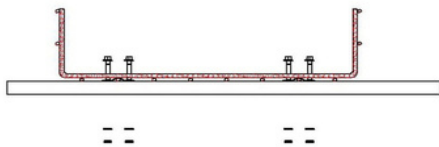

Product Details



Typical Installation



Welding Techniques



DURATRAY

cable basket



Email

sales@dura-tray.com



Social Media

[Duratray Thailand](#)



Call us

02-194 1138-9



Address

24/19 Moo7, Lampho, Bangbuathong, Nontaburi, 11110

